

IMPACT ACOUSTIC®

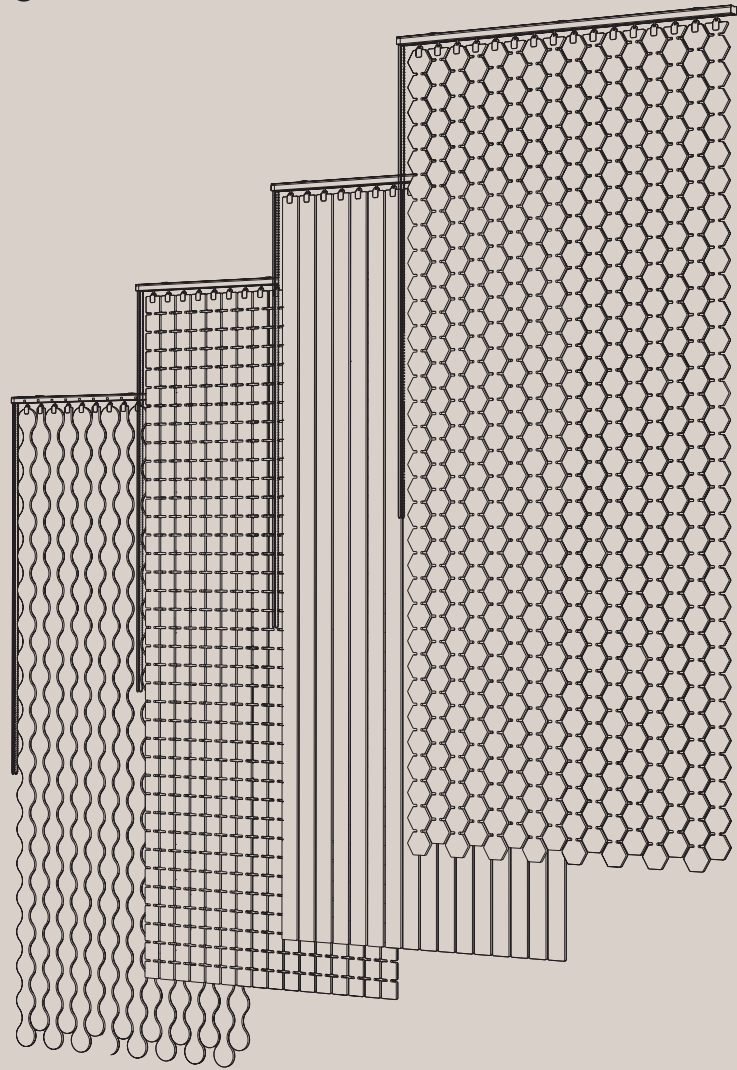

Pixels *by Rafa Ortega*

Retractable Room Division

746.12.01.000.00

746.12.02.000.00

746.12.03.000.00

746.12.04.000.00

TECHNICAL DATA SHEET

Pixels Retractable Room Division

General Information

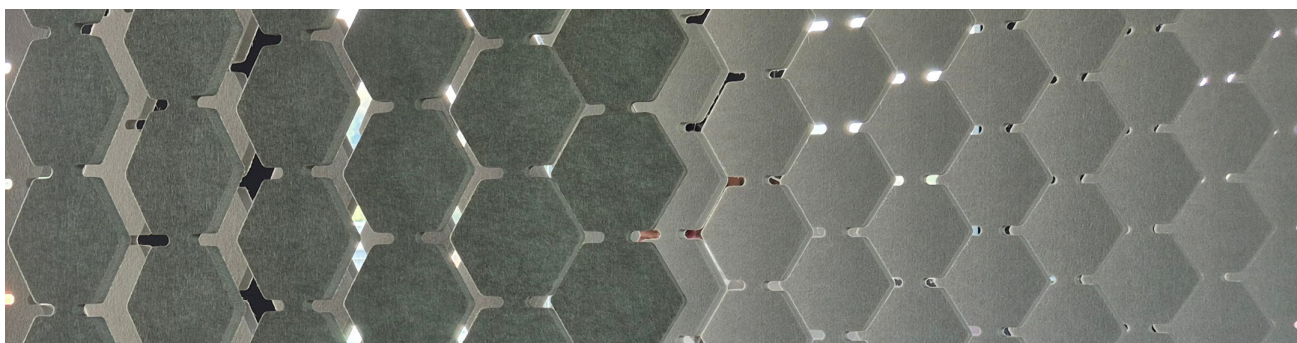

Data

Applicable article numbers

SQUARE	HEX	DROP	PLAIN
746.12.01.000.00	746.12.02.000.00	746.12.03.000.00	746.12.04.000.00

Dimensions¹

Height	2820mm	111"
Length	1250mm	49 1/4" <i>custom length upon request - see page 6</i>

Material

Vertical Slats	Archisonic® Felt - 100% PET (60% Post-consumer) in 36 colors
Rail	Steel (RAL9005)

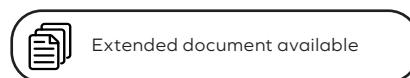

Weight²

Full assembly	8.8 kg (±10%)	19.4 lbs (±10%)
---------------	---------------	-----------------

Included

Acoustic Vertical Slats

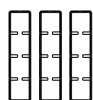

Rails and components



Installation guide



Warranty 2 years³



1 - all dimensions are nominal 2 - all weight values are nominal 3 - Impact Acoustic warranty terms apply

Pixels Retractable Room Division

Specification Guide

Ensure you make the perfect choice by choosing our solutions for your next project. To get started, simply define some basic information and constraints about your space. Then explore our range of standard solutions or contact us directly for a more in-depth discussion of personalized customized options.

1 Prepare this information:

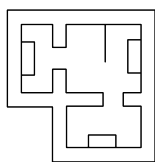

Project Area

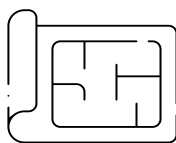

Ceiling Plans (RCP)



Other Considerations

2 Specify your design options:

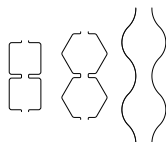

Shape

page 6

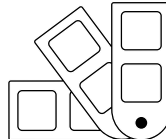

Colors

page 11

Pixels Retractable Room Division

Product Family Overview

1 Pixels Retractable Room Division SQUARE - 1250mm (49 1/4") 746.12.01.000.00

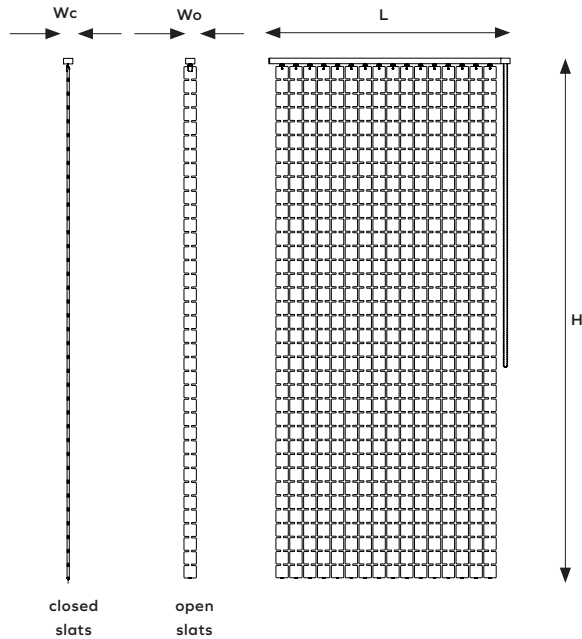

Dimensions¹

W_o	Total width (open slats)	67mm / 2.6"
W_c	Total width (closed slats)	50mm / 2"
L	Total length	1250mm / 49 1/4"
H	Total height	2821mm / 111"
P	Archisonic® Felt	12mm / 0.47"

2 Pixels Retractable Room Division HEX - 1250mm (49 1/4") 746.12.02.000.00

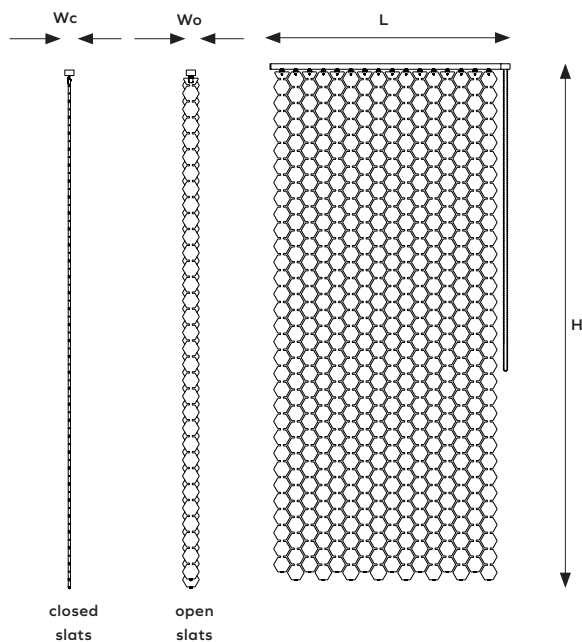

Dimensions¹

W_o	Total width (open slats)	89mm / 3.5"
W_c	Total width (closed slats)	50mm / 2"
L	Total length	1250mm / 49 1/4"
H	Total height	2816mm / 110.8"
P	Archisonic® Felt	12mm / 0.47"

¹ - All dimensions are nominal

Pixels Retractable Room Division

Product Family Overview

3 Pixels Retractable Room Division DROP - 1250mm (49 1/4") 746.12.03.000.00

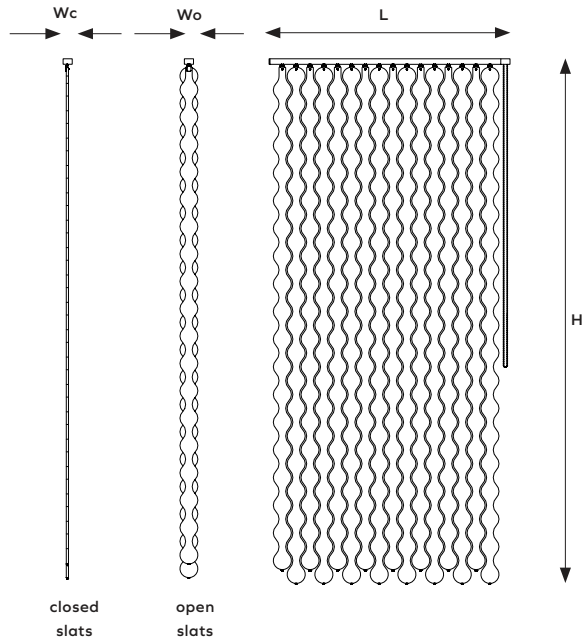

Dimensions¹

Wo	Total width (open slats)	98mm / 3.9"
Wc	Total width (closed slats)	50mm / 2"
L	Total length	1250mm / 49 1/4"
H	Total height	2853mm / 112.3"
P	Archisonic® Felt	12mm / 0.47"

4 Pixels Retractable Room Division PLAIN - 1250mm (49 1/4") 746.12.04.000.00

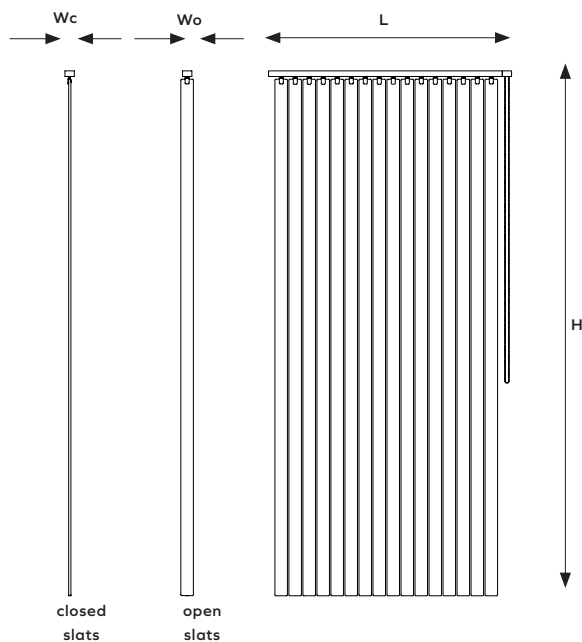

Dimensions¹

Wo	Total width (open slats)	67mm / 2.6"
Wc	Total width (closed slats)	50mm / 2"
L	Total length	1250mm / 49 1/4"
H	Total height	2821mm / 111"
P	Archisonic® Felt	12mm / 0.47"

1 - All dimensions are nominal

Pixels Retractable Room Division

Custom product width¹

Standard product length of 1250mm can be modified **upon request only for orders above 50lm /160lf of total length**. The minimum available length of the profile is L_{min} **650mm/25.6"** and the maximum length is L_{max} **1400mm/55.12"**. The length can be only modified in modules of **M 75mm/2.95"**.

Please note that **custom lead time and pricing** will apply. Contact us for more detail.

For the reference, see drawing below.

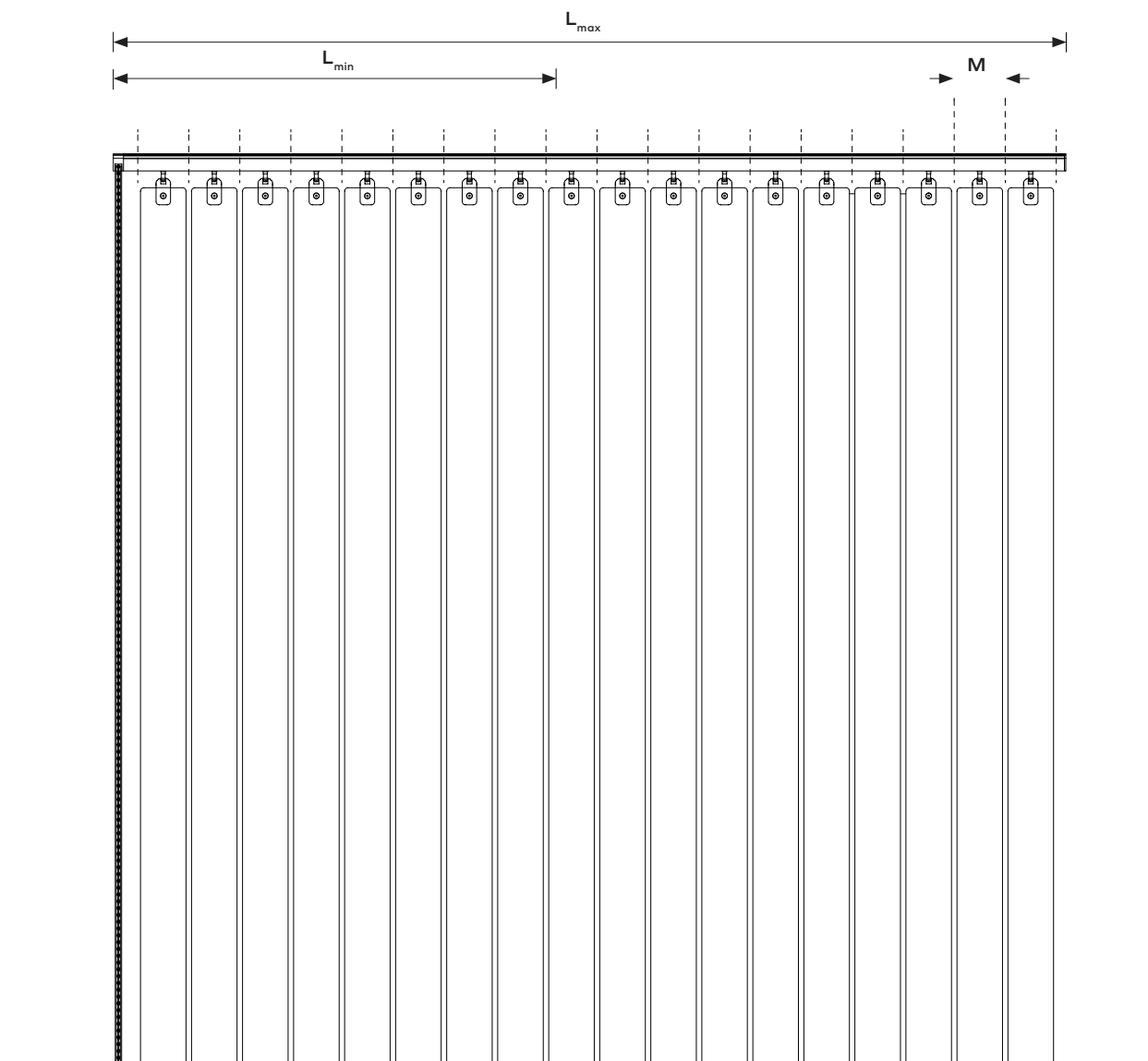

¹ - All dimensions are nominal

Pixels Retractable Room Division

Available Shapes

1 Square

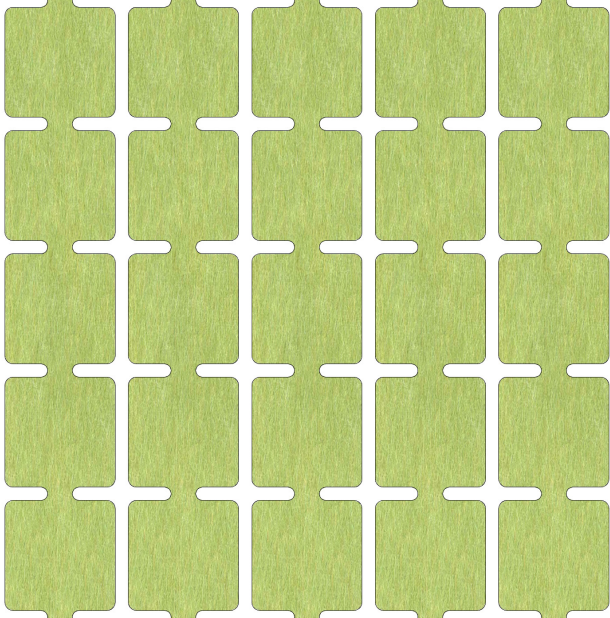

2 Hex

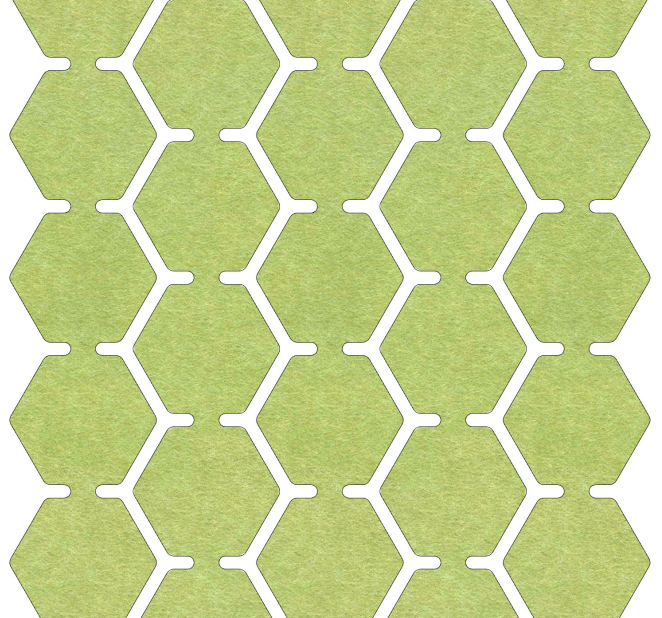

3 Drop

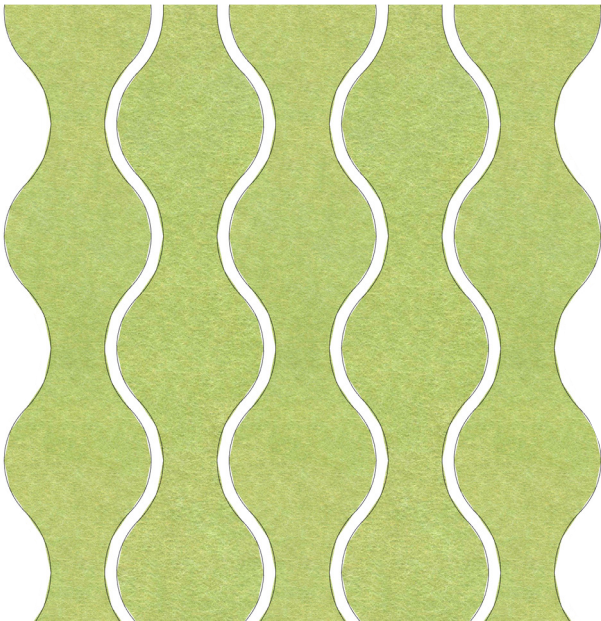

4 Plain

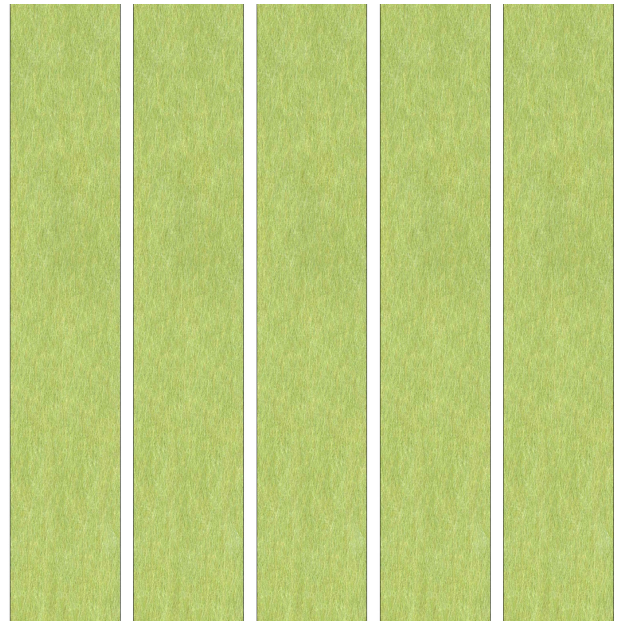

NOTE: Only a portion of the product is represented here

Pixels Retractable Room Division Sliding System

Operations

The mechanism on this vertical curtain division allows for the following operations:

Sliding slats from a stacked position to an extended position

Rotating slats for an open or closed position

Extended Open Position

Extended Open Position

Extended Closed Position

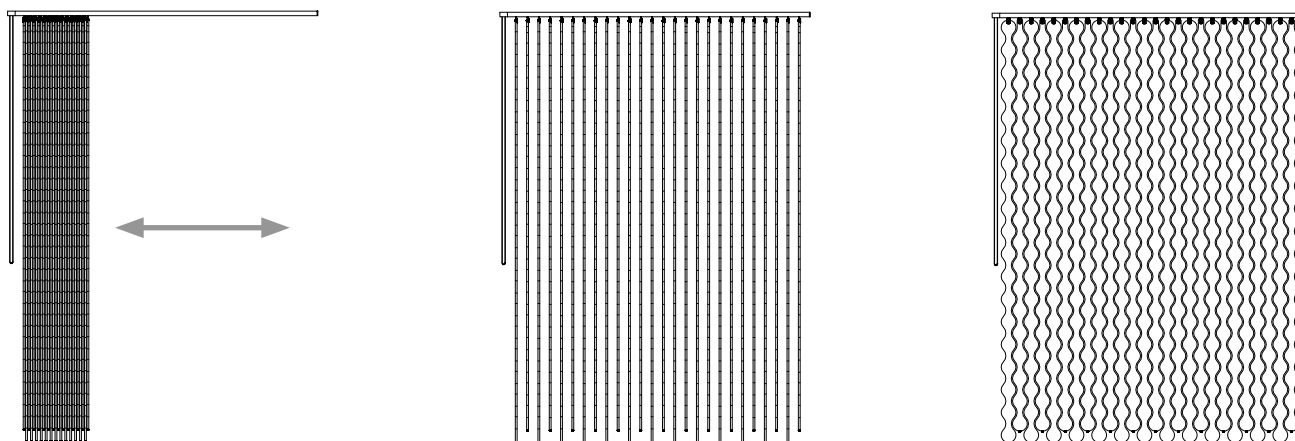

Sliding

The sliding always happen in the same direction. When the vertical slats are stacked, they remain close to the chain mechanism. If you want to change the direction of the sliding, you can always rotate the whole module in the horizontal plane by 180° upon installation.

Stacked Slats on the Left

Stacked Slats on the Right

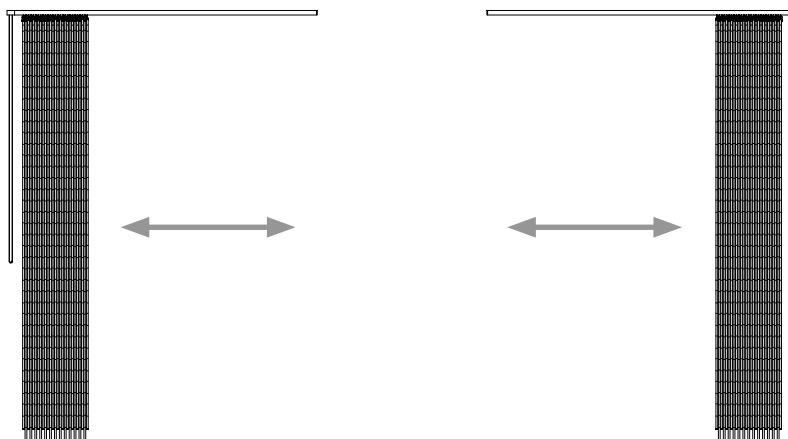

NOTE: Only one Length and Shape Option of this product is represented here. The same information applies to all product options.

Pixels Retractable Room Division

Combination of Modules

It is possible to install the modules right next to each other to create different configurations. It is important to note that you will have to plan this properly so that the chain system for operating the curtains remains at an optimal location.

Below you will see an example of how to combine two modules for a centered opening.

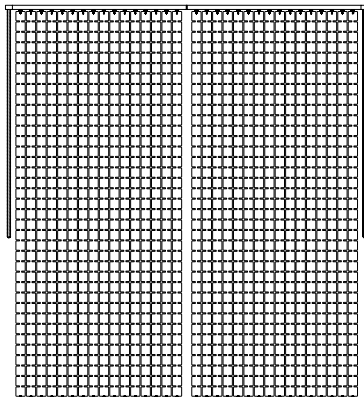

Extended Closed Position

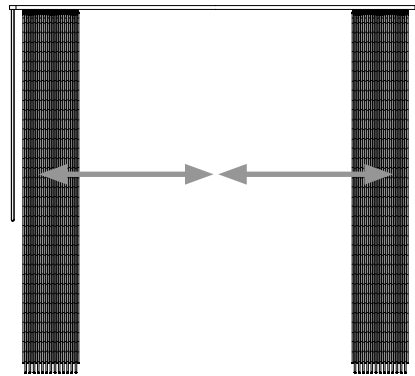

Stacked Position

On the example above you will notice the following:

- These modules are symmetrical, so there will be an opening in the center that indicates where the curtain will open. This can be changed upon installation !
- There will be two different chain mechanisms located at each side to operate each module independently.

On-site adjustments

The height of the slats can be adjusted on site if needed. For this, we recommend to cut the slats at the junction between the shapes, following the diagram below:

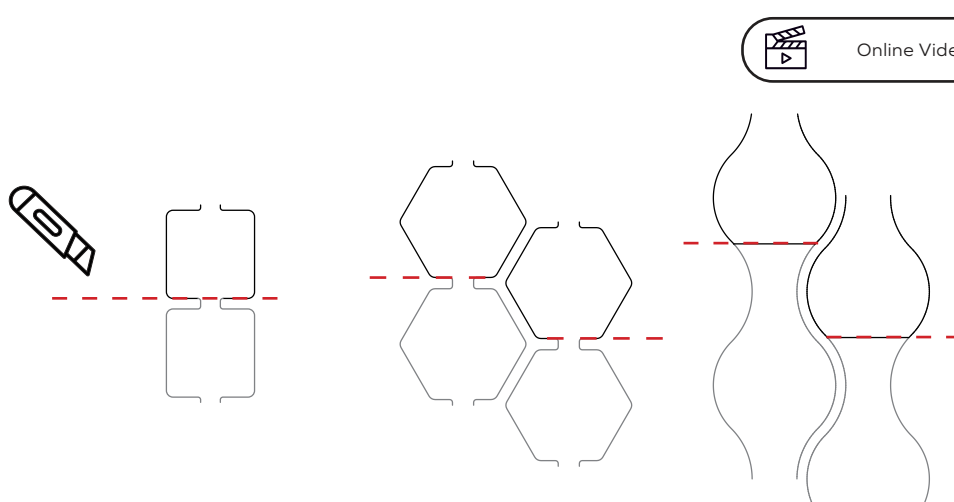

Please note no modifications to the length of the rail can be made on site. The mechanism inside the rail has been specifically assembled for the rail's length. If you require custom lengths, contact our Project Management Team.

Pixel Retractable Room Division

Components

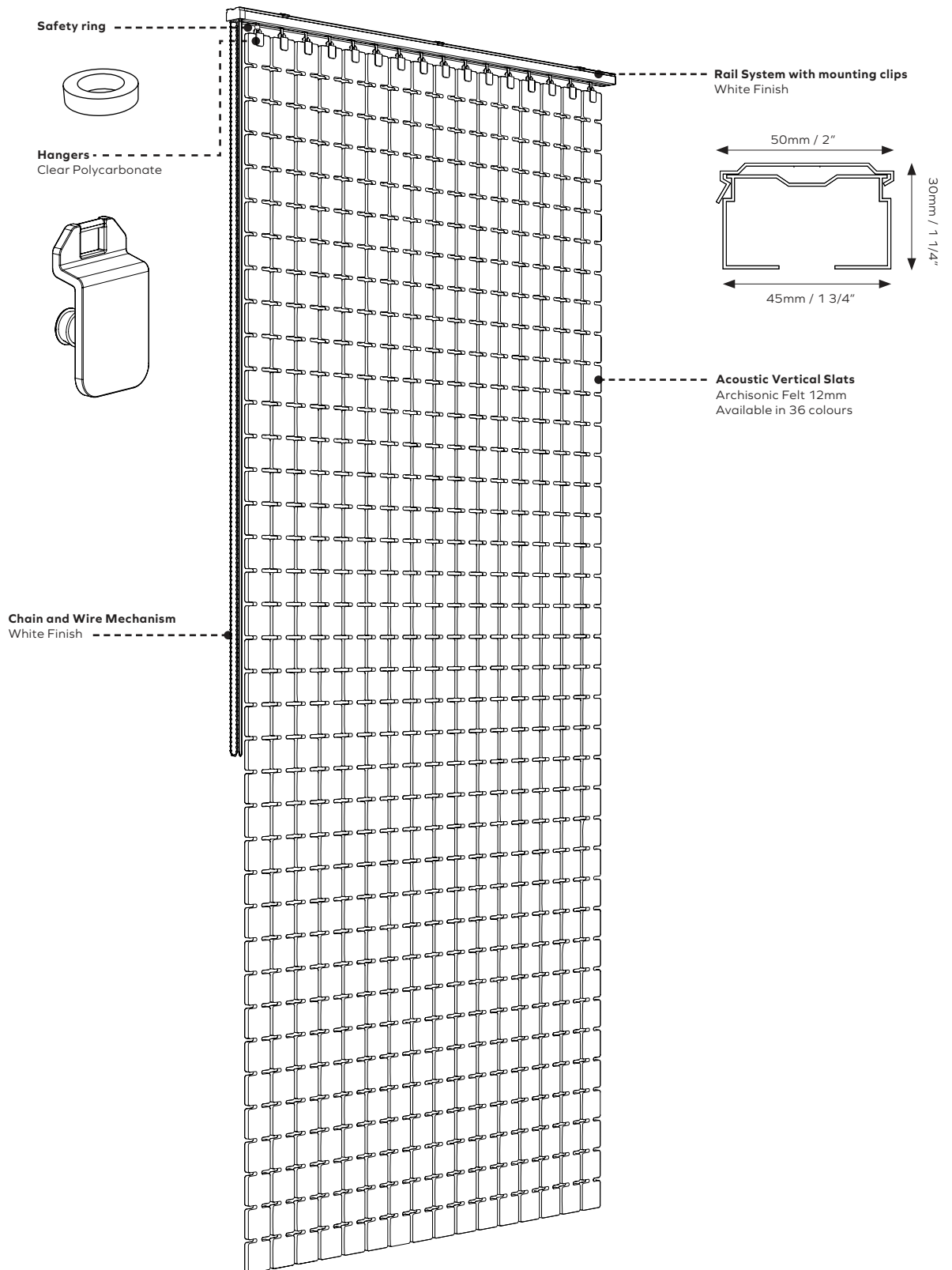

All dimensions are nominal

Pixels Retractable Room Division

Installation Overview

1 Install the rail and fix the hangers

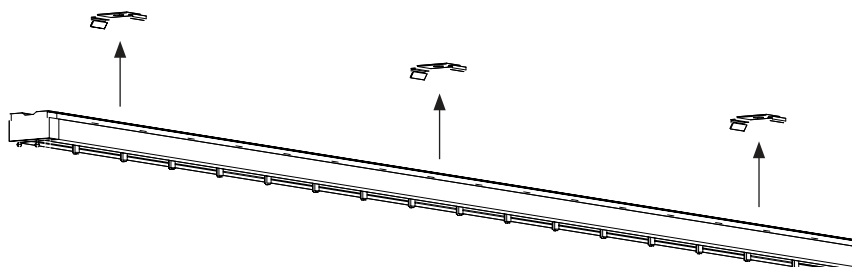

2 Attach hangers to the slats

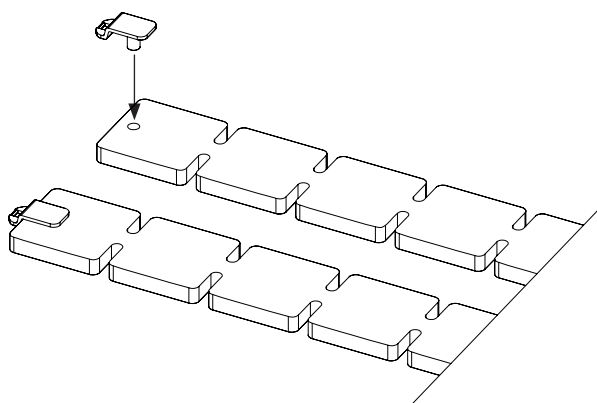



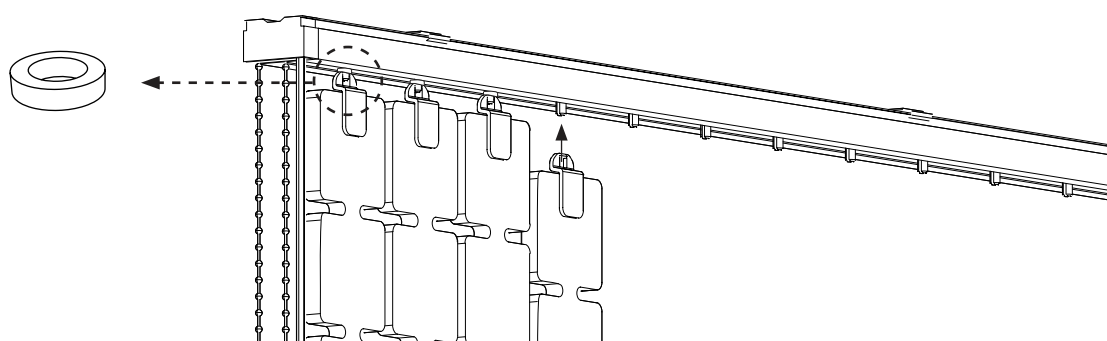







4 Secure the interface clips with the safety rings and fix slats to hangers











ARCHISONIC® Felt Colors

 Material brochure available

									
Name	Snow White	Milk	Cloud	Gull	Smoke	Ground	Charcoal	Slate	Raven
Code	500	404	103	144	442	108	542	444	550
NCS	S 0300-N	S 0502-Y	S 1002-B	S 2502-Y	S 3005-R80B	S 5005-Y20R	S 7502-B	S 4500-N	S 8500-N

									
Name	Nordic Pine	Grove	Fern	Moss	Spearmint	Ice Blue	Succulent	Deep Sea	True Navy
Code	311	317	180	439	706	304	712	918	194
NCS	S 5030-G10Y	S 7020-G30Y	S 6010-G90Y	S 2040-G40Y	S 1010-B90G	S 0510-B	S 3020-B30G	S 5020-R90B	S 8005-B

									
Name	Lichen	Linen	Shell Pink	Jute	Warm Stone	Terracotta	Soft Coral	Honeycomb	Sunshine
Code	160	107	102	920	105	239	516	139	846
NCS	S 4005-Y	S 1505-Y30R	S 0510-R30B	S 3010-Y30R	S 3010-Y50R	S 4040-Y70R	S 2020-Y90R	S 2050-Y20R	S 1040-Y10R

									
Name	Garnet	Hot Pink	Poster Red	Electric Orange	Winter Sky	Pacific Ocean	Midnight	Grape	Marine Blue
Code	724	140	662	464	410	432	810	540	864
NCS	S 5040-R10B	S 2060-R20B	S 1080-R	S 0580-Y70R	S 2020-R90 B	S 3040-B	S 7020-R70B	S 5040-R40B	S 4050-R70B

These NCS codes are the closest visual match available and may not be exact to blended fibres.

ARCHISONIC®

Colors

Experience our ARCHISONIC® Felt material with a stunning selection of 36 colors across 8 distinct families, thoughtfully curated by *Colour Hive* in London. Effortlessly combine colors harmoniously to suit your preferences. Discover more in our Materials brochure and order your free sample box today.

Color fastness

Class 6

ISO 105-B02:A1

Order a free sample box



Pixels Retractable Room Division

Tender Text

Product Name	Pixels Retractable Division	
Content	Archisonic Felt 12mm 100% PET (60% certified post-consumer content) Steel Rails	
Sizes	2850mm (H) x 1250mm (L) <i>(Height ranges from 2816mm - 2853mm, depending on the variation)</i>	
Density¹	2.4 Kg/m ² (0.49 lbs/sqft)	
Acoustic²	EN ISO 354:2003: $\alpha_w=0.4(H)$	ASTM C423-17: NRC=0.40
Colors and finishes	36 colors (see Archisonic® Felt Color page for more information)	
Fire Rating	DIN EN 13501-1: B-s1, d0	ASTM E84 Class A
Warranty & Support	2-Year warranty ³ . Design support (incl. 1x revision).	
Maintenance	For daily cleaning we recommend alcohol solution (75%), e.g. Pantasept. In case of contamination by dust or fluff, use feather duster or a regular vacuum cleaner. For heavy dirt, treat the material with hydrogen peroxide.	
Other Certificates	Breeam® (International, UK, NL, SE, NOR) Exemplary , Declare label, Cradle to Cradle, UL Environmental Product Declaration, Member of US Green Building Council, Ecobau 1st Priority, Climmate-KIC, VOC emissions in LEED EQ credit (low-emitting products), SCS Recycled Content, 28 Days French Regulation A+ , CDPH (CDPH/EHLB/Standard Method V1.2) Pass , ISO 105-B02:A Class 6 .	

1 - all values are nominal

2 - acoustic data refers to Archisonic Felt 12mm material

3 - Impact Acoustic warranty terms apply



Climate-KIC is supported by the EIT, a body of the European Union



Pixels Retractable Room Division

Acoustic Performance



Testing Standards

ISO 354:2003	Acoustics — Measurement of sound absorption in a reverberation room
ISO 11654:1997	Acoustics — Sound absorbers for use in buildings — Rating of sound absorption
ISO 20189:2018	Acoustics — Screens, furniture and single objects intended for interior use — Rating of sound absorption and sound reduction of elements based on laboratory measurements
ASTM C423-17	Standard Test Method for Sound Absorption and Sound Absorption Coefficients by the Reverberation Room Method
ASTM E795-16	Standard Practices for Mounting Test Specimens During Sound Absorption Tests

Acoustic Test Results

	α_w	SAA	NRC
12mm Hanging Partition 1200x2800mm (Plain)	0.4 (H)	0.39	0.40
12mm Hanging Partition 1200x2800mm (Perforated pattern)	0.35 (H)	0.32	0.35

The NRC rating is calculated as the average of the absorption coefficients measured at frequencies of 250Hz, 500Hz, 1000Hz and 2000Hz and round to the nearest 0.05. SAA rating is calculated as the average of the sound absorption coefficients of a material for the twelve one-third octave bands from 200Hz through 2500Hz and rounded off to the nearest 0.01.

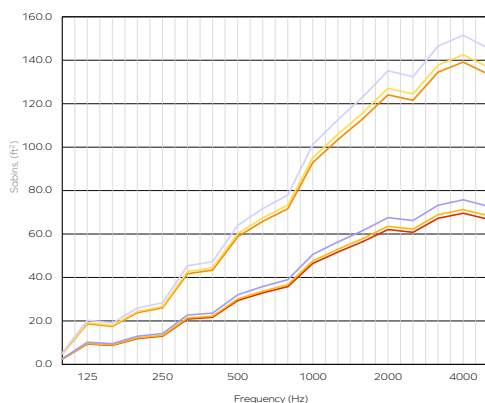

Acoustic Performance - ASTM Sabins , ft²

Frequency (Hz)	Length	125	250	500	1000	2000	4000
12mm Pixel	2000mm	6.5	15.1	28.0	44.1	60.3	67.8
12mm Pixel	4000mm	14.0	30.1	56.0	89.3	119.5	135.6
12mm Hexagon	2000mm	7.5	16.1	29.1	45.2	61.4	70.0
12mm Hexagon	4000mm	14.0	31.2	57.0	91.5	122.7	138.9
12mm Drop	2000mm	7.5	16.1	30.1	48.4	64.6	74.3
12mm Drop	4000mm	15.1	33.4	61.4	96.9	130.2	147.5

The graph represents the Sabins (ft²) in the third octave band center frequencies in accordance with ASTM C423.

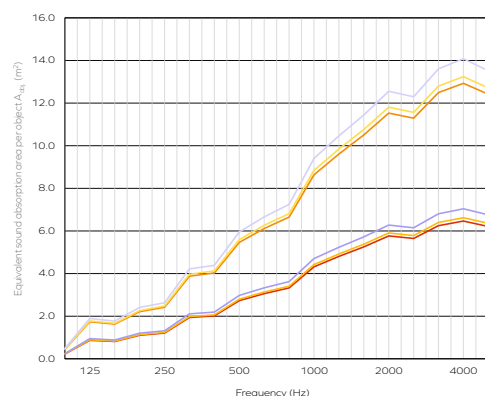

Acoustic Performance - ISO A_{obj} , m²

Frequency (Hz)	Length	125	250	500	1000	2000	4000
12mm Pixel	2000mm	0.6	1.4	2.6	4.1	5.6	6.3
12mm Pixel	4000mm	1.3	2.8	5.2	8.3	11.1	12.6
12mm Hexagon	2000mm	0.7	1.5	2.7	4.2	5.7	6.5
12mm Hexagon	4000mm	1.3	2.9	5.3	8.5	11.4	12.9
12mm Drop	2000mm	0.7	1.5	2.8	4.5	6.0	6.9
12mm Drop	4000mm	1.4	3.1	5.7	9.0	12.1	13.7

The graph represents the equivalent sound absorption per object (A_{obj}) in the third octave band center frequencies in accordance with ISO 20189. Measurement used Pink Noise as excitation signal in a reverberant room.

- 12mm Pixel 2000mm
- 12mm Pixel 4000mm
- 12mm Hexagon 2000mm
- 12mm Hexagon 4000mm
- 12mm Drop 2000mm
- 12mm Drop 4000mm

Pixels Retractable Room Division

Additional Information

Online Resources

A variety of resources are available online for all of our products. Please visit the product's page for more information.



CAD files



Spec sheets and
Installation Guide



Color families



Instruction
videos



Associated
products specs.

Ordering Process

Our experienced team of Project Consultants will guide and support you throughout the order process. We fulfill the majority of our orders in as little as 21 days¹ from your first point of contact, allowing you to focus on what truly matters to you.



Contact our
consultant

Quote¹

48h



Order Confirmation

Production¹

6 - 8 Weeks



Dispatch

Transit

location based



Delivery

Contact Us

Ready to make an impact? We are just an email or call away to discuss your project and answer any question.



+41 41 244 14 00



connect@impactacoustic.com



Online form

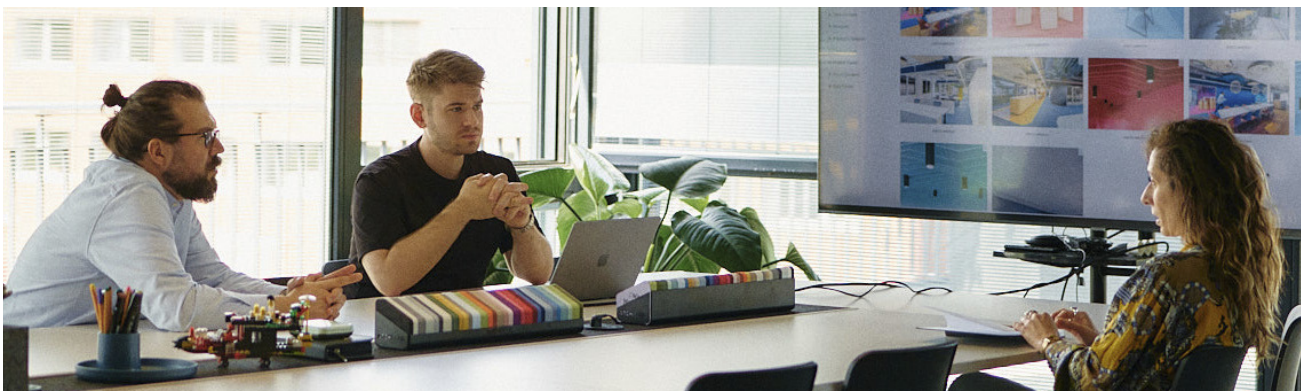

¹ - Quote and Production times may vary.

**#We
Make An
Impact**

connect@impactacoustic.com | www.impactacoustic.com