

IMPACT ACOUSTIC®

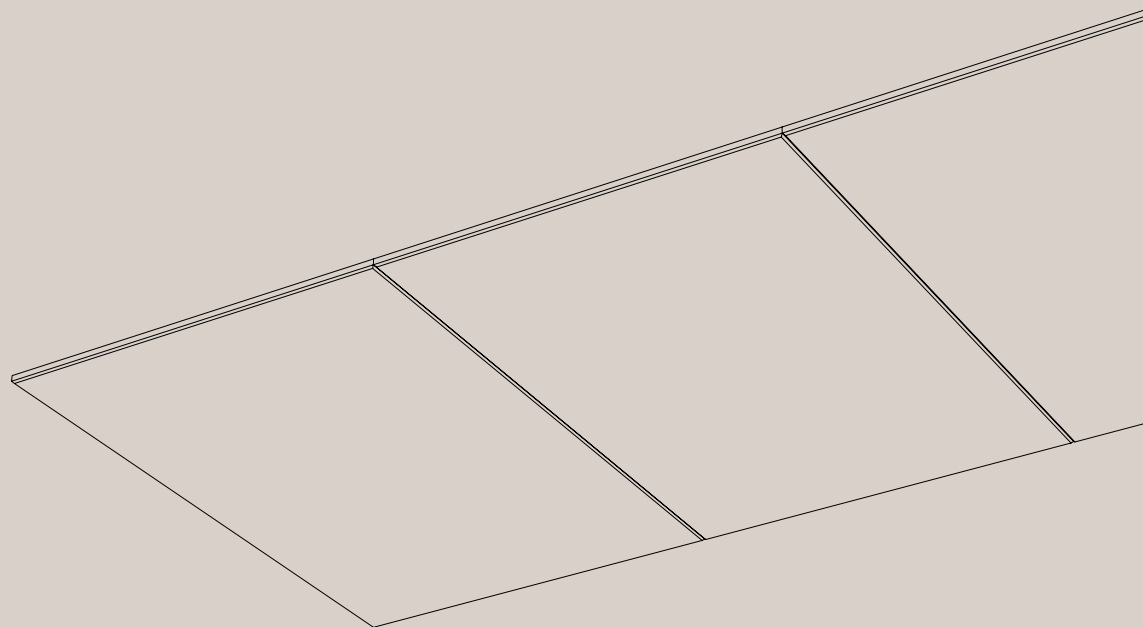

# Alto

## Ceiling Panels

711.24.31.000.00  
711.24.32.000.00

TECHNICAL DATA SHEET

# Alto Ceiling Panels

## General Information



### Data

#### Applicable article numbers

711.24.31.000.00      711.24.32.000.00

#### Single element dimensions<sup>1</sup>

Width	1200 mm	47 1/4"	
Length	1800 mm	70 3/4"	
Thickness	24 mm	1"	(without substructure)
Total thickness	44 mm	1 3/4"	

#### Material

Panel                                      100% PET (60% post-consumer) in 36 colors  
Substructure Profiles                  Aluminum anodized black

#### Weight<sup>2</sup>

Panel	8kg (±10%)	17.5 lbs (±10%)	(without substructure)
Substructure Profiles	1.5 (±10%)	3.3 lbs (±10%)	(weight of 3 profiles)

### Included

Alto Panel



Stiffening profiles  
x3 + 1 spare

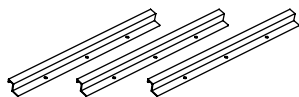

Installation  
guide



Warranty  
10 years<sup>3</sup>



1 - all dimensions are nominal    2 - all weight values are nominal

# Alto Ceiling Panels

## Geometry Information<sup>1</sup>

711.24.31.000.00 - Alto Ceiling Panel

FRONT



SIDE

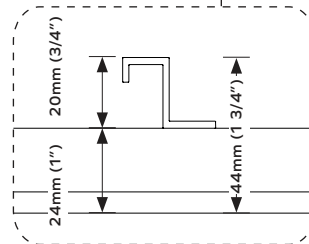
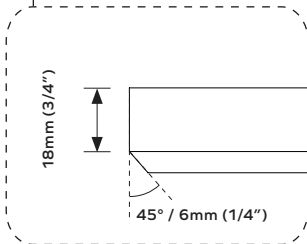
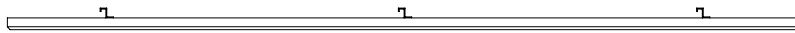

BACK

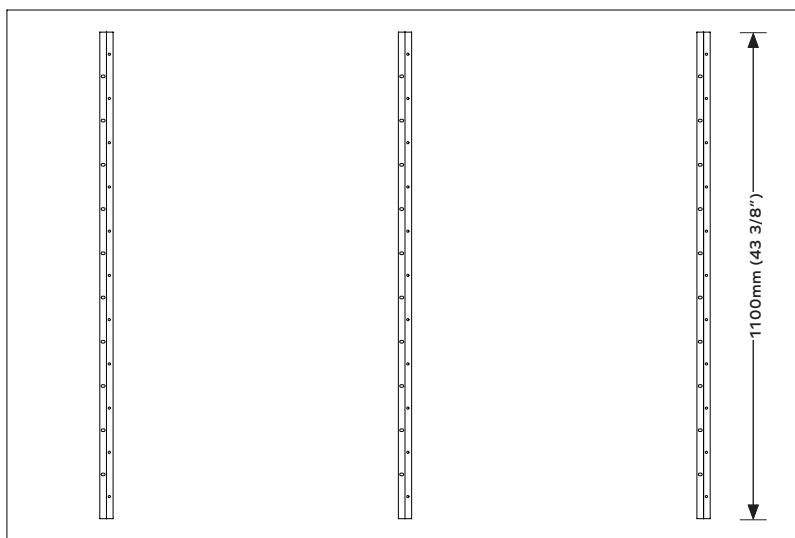

Recommended profiles positioning<sup>2</sup>

1 - all dimensions are nominal 2 - The structural profiles are installed on site. The exact positioning can be adjusted by the installer.

# Alto Ceiling Panels

## Geometry Information<sup>1</sup>

711.24.32.000.00 - Alto Ceiling Panel - Vertigo Fine

FRONT

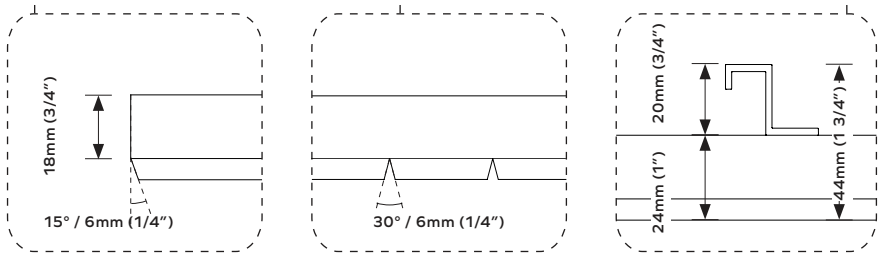
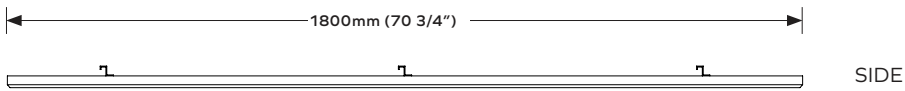
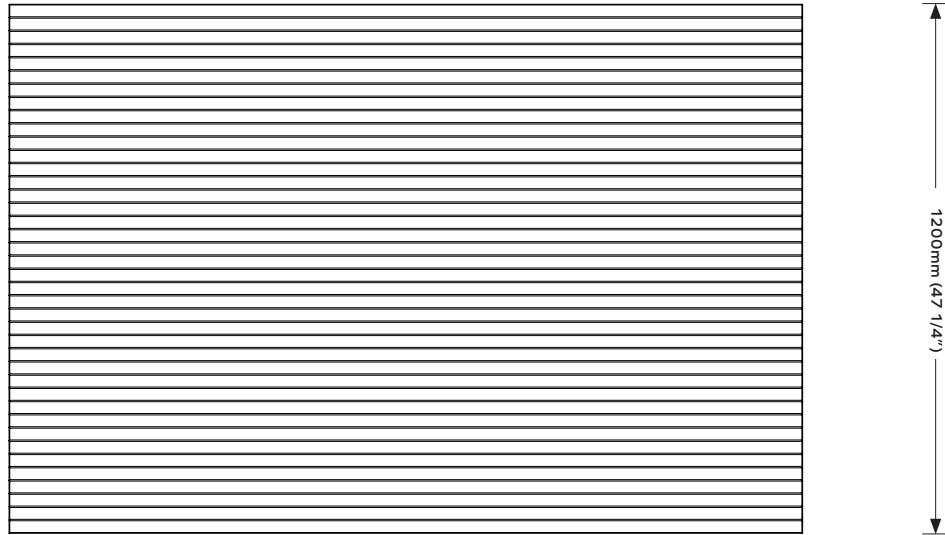

BACK

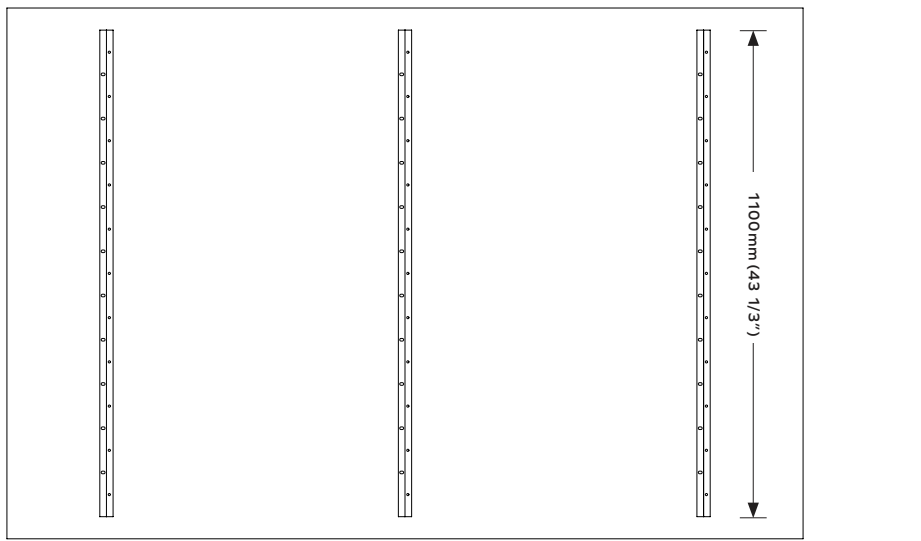

231mm (9")    650mm (25 9/16")    650mm (25 9/16")    231mm (9")  
 Recommended profiles positioning<sup>2</sup>

1 - all dimensions are nominal    2 - The structural profiles are installed on site. The exact positioning can be adjusted by the installer.

# Alto Ceiling Panels

## Geometry Information

711.24.31.000.00 - Alto Ceiling Panel

### Front side perspective

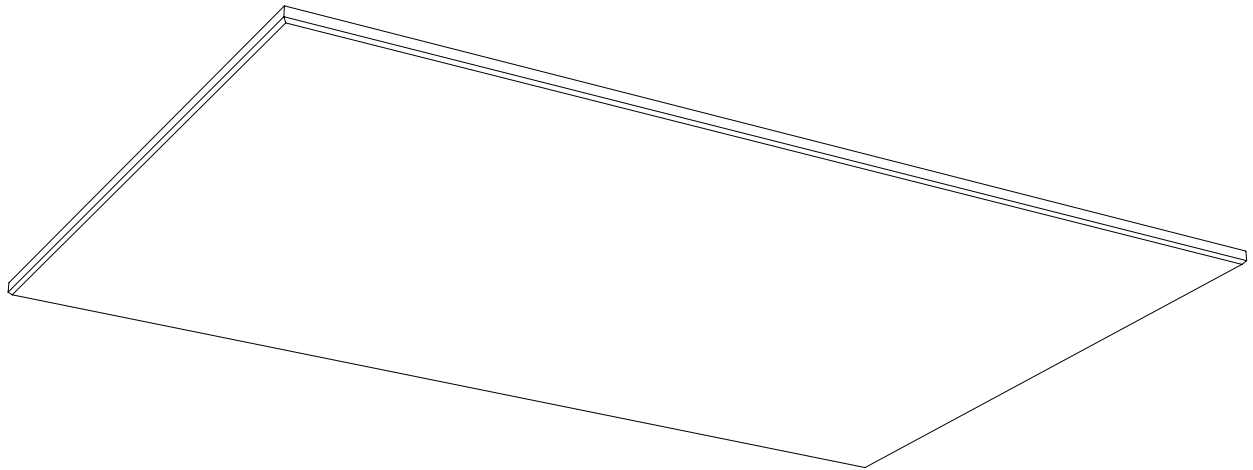

### Back side perspective

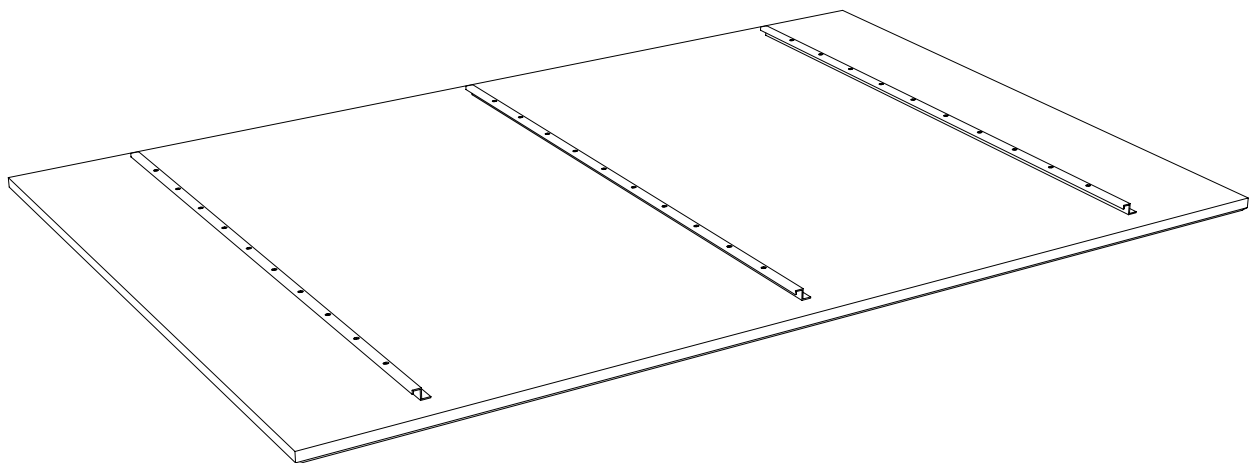

<sup>1</sup> all dimensions are nominal

# Alto Ceiling Panels

## Geometry Information

711.24.32.000.00 - Alto Ceiling Panel - Vertigo Fine

### Front side perspective

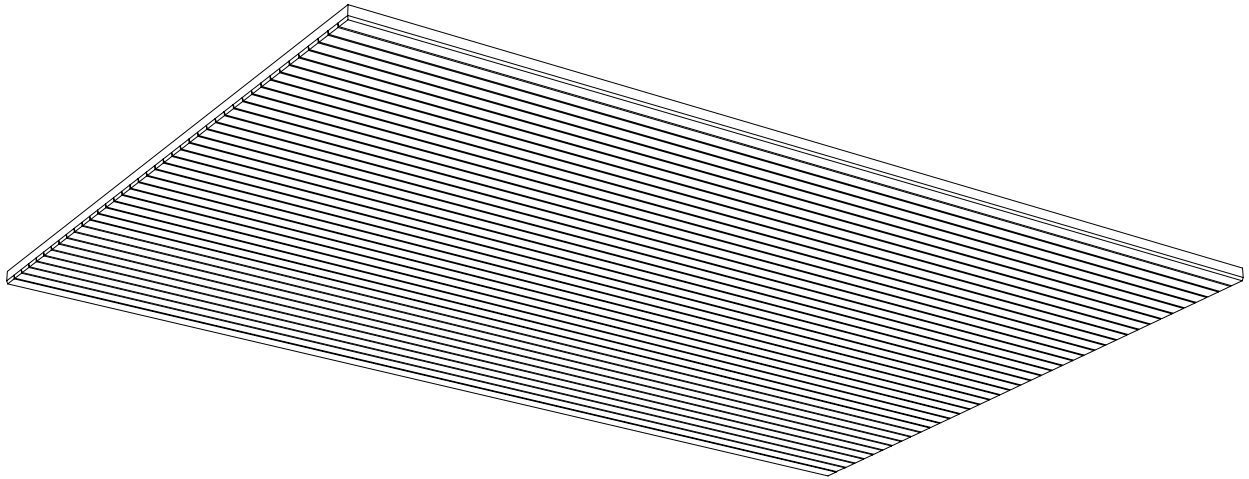

### Back side perspective

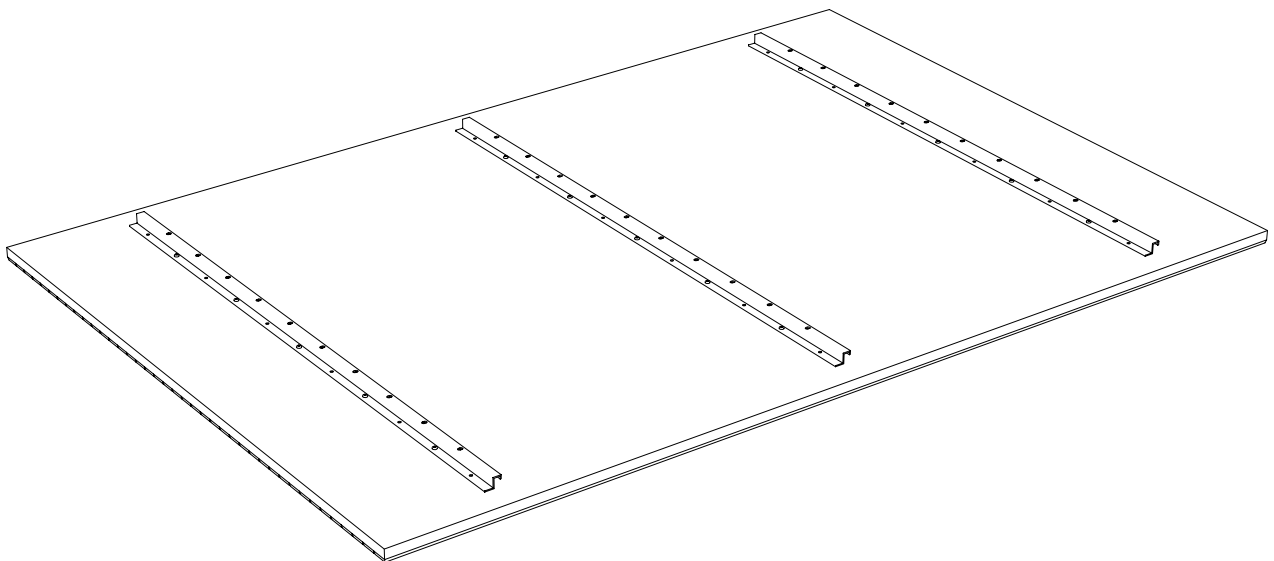

<sup>1</sup> all dimensions are nominal

# Alto Ceiling Panels

## Assembly Guide

### 1 Install stiffening profiles at the back of the panel using the provided screws

We recommended placing the profiles in a module described on a page 3. Installers can make adjustments on site.

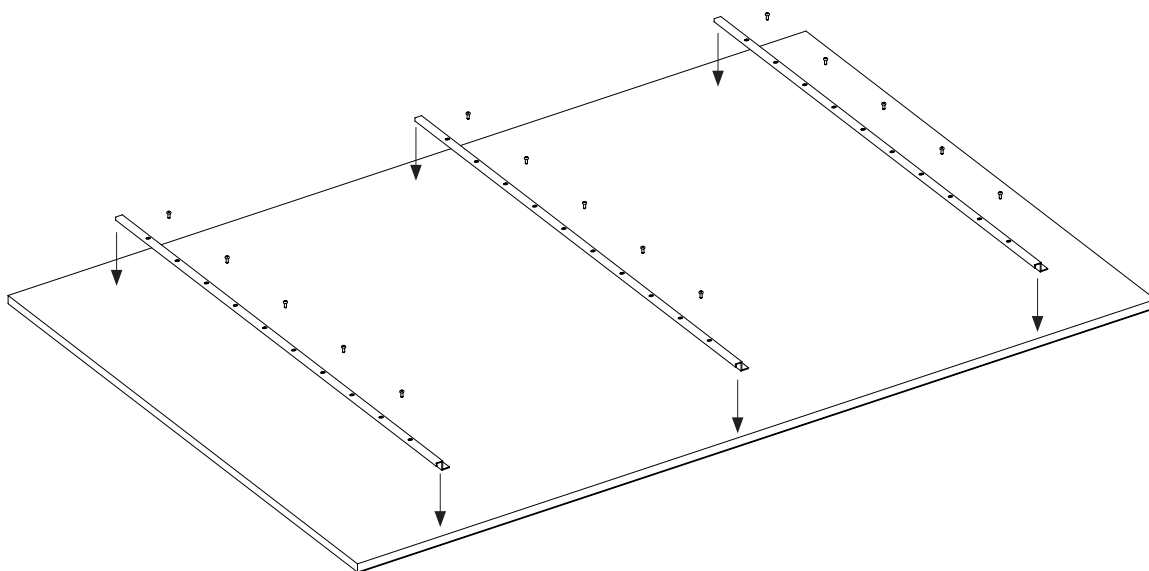

### 2 Mounting hardware

Depending on the selected mounting method, install included mounting hardware.

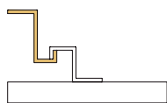

**Profile to profile**

secondary profile not included.

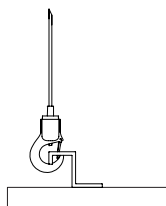

**Cable hook to profile**

822.10.00.597.00

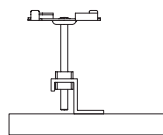

**T-Grid Clip to profile**

716.10.30.000.00

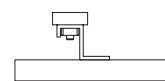

**Magnet to profile**

716.10.40.000.00

<sup>1</sup> all dimensions are nominal

# Alto Ceiling Panels



Extended document available

## Installation Overview

### 1 Primary and secondary 3rd party substructure

For the ceiling substructure we recommend using **Suspension System for METAL Ceilings METAL U-Profile + J-Bar** from **KNAUF Ceiling Solutions**. Essential elements are listed below:

- M300100 U-Profile
- M300119 Splice connector for U-Profile
- M300120 Plug-in clip for U-Profile
- M3001211 Clamping bracket for U-Profile
- M300026 J-Bar
- M300343B Splice connector for J-Bar
- M300307C Hanger for J-Bar

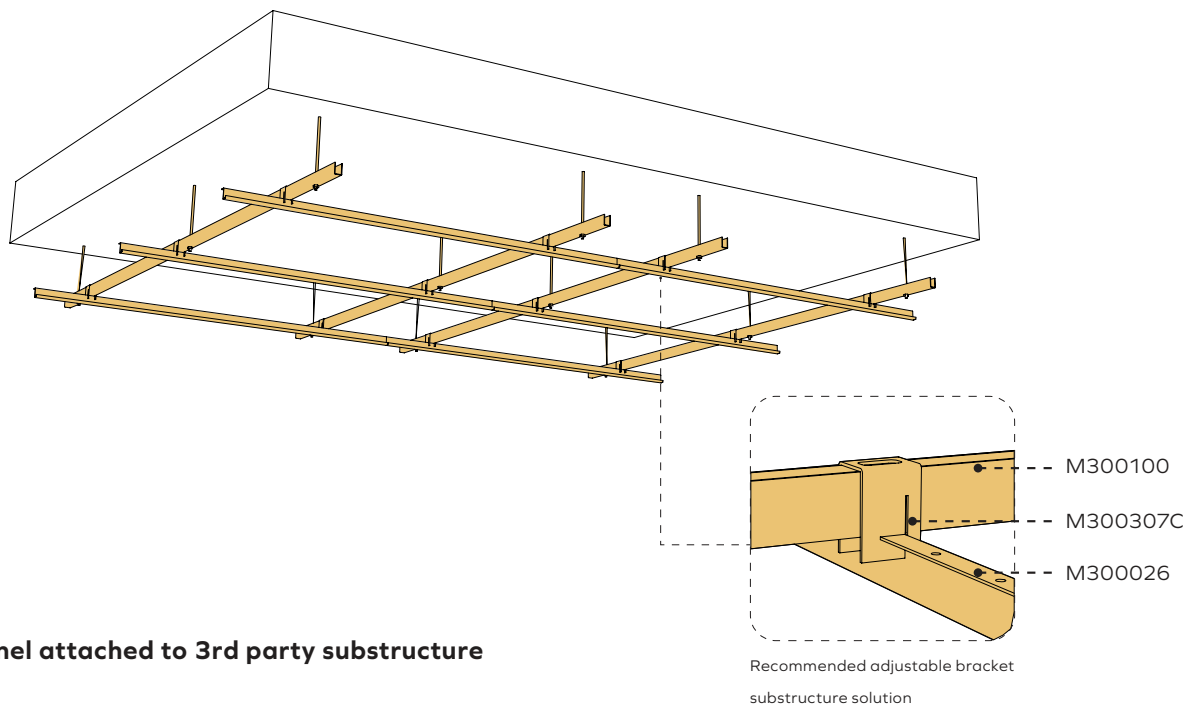

### 2 Alto panel attached to 3rd party substructure

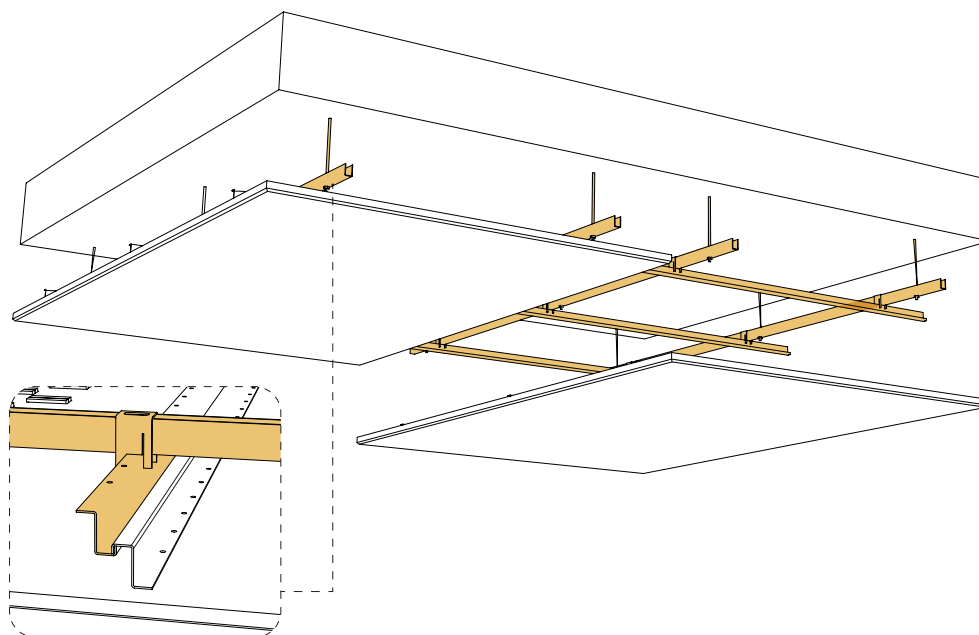

To mount the Alto panels use the channel u shaped or similar profiles.

# Alto Ceiling Panels

## Installation Overview

### 3 On-Site adjustments.

Archisonic® Felt can be cut on site to specific length using carpentry knife or rotary circular saw for wood (ex. Bosch Ø160 x 2,2/1,6 x 20mm, 48HW blade for wood). Make sure blade does not get hot, this could cause the Felt material to melt and the edge to deform. Please cut the Felt while flat on the ground before the assembly. The aluminum profiles can also be trimmed using the metal jigsaw or rotary blade.

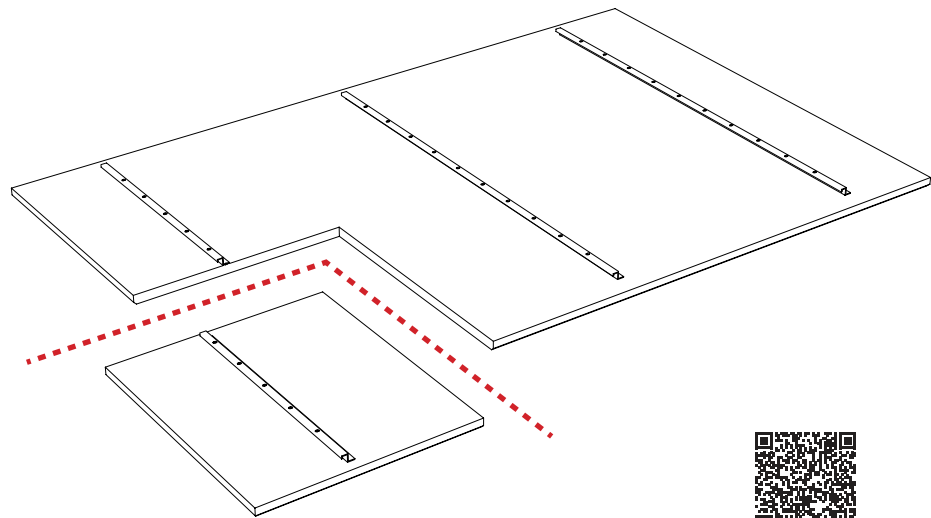
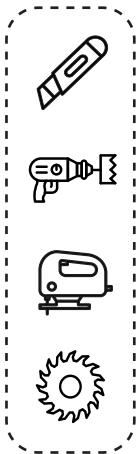

### 4 Final assembly of Alto panels

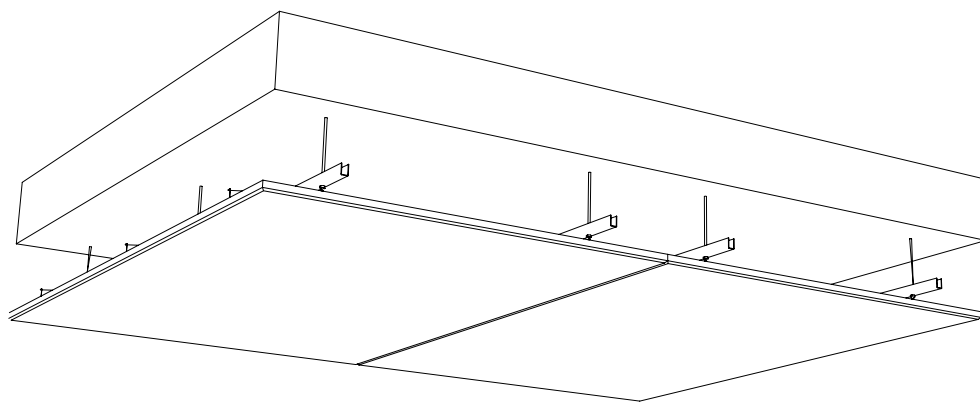

# Alto Ceiling Panels

## Acoustic Performance

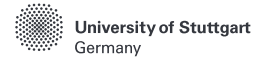

### Testing Standards

ISO 354:2003	Acoustics — Measurement of sound absorption in a reverberation room
ISO 11654:1997	Acoustics — Sound absorbers for use in buildings — Rating of sound absorption
ISO 20189:2018	Acoustics — Screens, furniture and single objects intended for interior use — Rating of sound absorption and sound reduction of elements based on laboratory measurements
ASTM C423-17	Standard Test Method for Sound Absorption and Sound Absorption Coefficients by the Reverberation Room Method
ASTM E795-16	Standard Practices for Mounting Test Specimens During Sound Absorption Tests

### Acoustic Test Results

	$\alpha_w$	SAA	NRC
24mm Alto	0.95	0.95	0.90

1 - Measured with 300mm airgap

The NRC rating is calculated as the average of the absorption coefficients measured at frequencies of 250Hz, 500Hz, 1000Hz and 2000Hz and round to the nearest 0.05. SAA rating is calculated as the average of the sound absorption coefficients of a material for the twelve one-third octave bands from 200Hz through 2500Hz and rounded off to the nearest 0.01.

### Acoustic Performance

Frequency (Hz)		125	250	500	1000	2000	4000
24mm Alto	$\alpha_p$	0.70	0.85	0.85	0.95	1.00	1.00

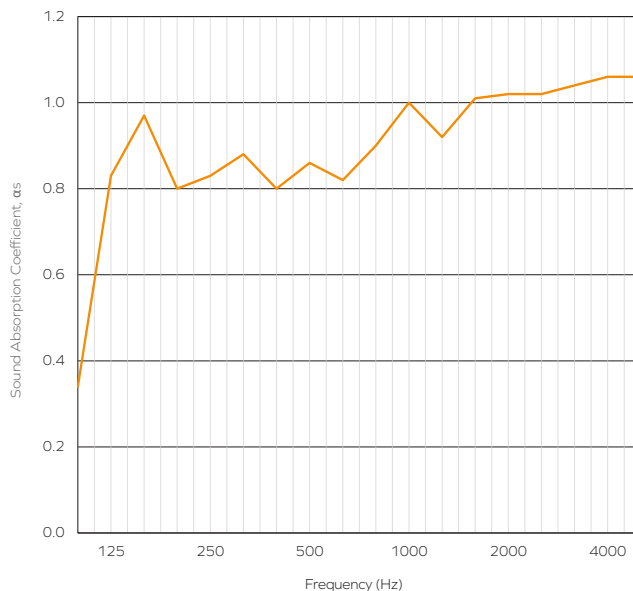















● 24mm Alto

The table represents the practical sound absorption coefficient ( $\alpha_p$ ) in accordance with ISO 11654. The graph represents the sound absorption coefficients ( $\alpha_s$ ) in the third octave band center frequencies in accordance with ISO 354. Measurement used Pink Noise as excitation signal in a reverberant room.









# ARCHISONIC® Felt Colors

 Material brochure available

									
<b>Name</b>	Snow White	Milk	Cloud	Gull	Smoke	Ground	Charcoal	Slate	Raven
<b>Code</b>	500	404	103	144	442	108	542	444	550
<b>NCS</b>	S 0300-N	S 0502-Y	S 1002-B	S 2502-Y	S 3005-R80B	S 5005-Y20R	S 7502-B	S 4500-N	S 8500-N

									
<b>Name</b>	Nordic Pine	Grove	Fern	Moss	Spearmint	Ice Blue	Succulent	Deep Sea	True Navy
<b>Code</b>	311	317	180	439	706	304	712	918	194
<b>NCS</b>	S 5030-G10Y	S 7020-G30Y	S 6010-G90Y	S 2040-G40Y	S 1010-B90G	S 0510-B	S 3020-B30G	S 5020-R90B	S 8005-B

									
<b>Name</b>	Lichen	Linen	Shell Pink	Jute	Warm Stone	Terracotta	Soft Coral	Honeycomb	Sunshine
<b>Code</b>	160	107	102	920	105	239	516	139	846
<b>NCS</b>	S 4005-Y	S 1505-Y30R	S 0510-R30B	S 3010-Y30R	S 3010-Y50R	S 4040-Y70R	S 2020-Y90R	S 2050-Y20R	S 1040-Y10R

									
<b>Name</b>	Garnet	Hot Pink	Poster Red	Electric Orange	Winter Sky	Pacific Ocean	Midnight	Grape	Marine Blue
<b>Code</b>	724	140	662	464	410	432	810	540	864
<b>NCS</b>	S 5040-R10B	S 2060-R20B	S 1080-R	S 0580-Y70R	S 2020-R90 B	S 3040-B	S 7020-R70B	S 5040-R40B	S 4050-R70B

These NCS codes are the closest visual match available and may not be exact to blended fibres.

**ARCHISONIC®**

## Colors

Experience our ARCHISONIC® Felt material with a stunning selection of 36 colors across 8 distinct families, thoughtfully curated by *Colour Hive* in London. Effortlessly combine colors harmoniously to suit your preferences. Discover more in our Materials brochure and order your free sample box today.

## Color fastness

Class 6

ISO 105-B02:A1

## Order a free sample box



# ARCHISONIC® Felt

## Material Specification

<b>Product Name</b>	Archisonic® Felt	
<b>Content</b>	100% PET (60% certified post-consumer content)	
<b>Thickness<sup>1</sup></b>	12mm (0.47")	24mm (0.94")
<b>Max. Size</b>	1200x2800mm (47"x110")	1800x2400mm (70"x94")
<b>Acoustic<sup>2</sup></b>	<b>ASTM:</b> NRC=0.6 <b>ISO:</b> $\alpha_w$ =0.65	<b>ASTM:</b> NRC=0.9 <b>ISO:</b> $\alpha_w$ =0.95
<b>Density<sup>1</sup></b>	2400 g/m <sup>2</sup> (0.49 lbs/ sqft)	4000 g/m <sup>2</sup> (0.82 lbs/sqft)
<b>Color Fastness</b>	<b>Class 6</b> ISO 105-B02:A1	
<b>Color</b>	<b>36 colors</b> (see Archisonic® Felt Color page for more information)	
<b>Maintenance</b>	For daily cleaning we recommend alcohol solution (75%), e.g. Pantasept. In case of contamination by dust or fluff, use feather duster or a regular vacuum cleaner. For heavy dirt, treat the material with hydrogen peroxide.	
<b>Production Lead time<sup>3</sup></b>	21 days	
<b>Fire Rating</b>	DIN EN 13501-1: <b>B-s1, d0</b>	ASTM E84 <b>Class A</b>
<b>VOC Emission</b>	28 Days French Regulation <b>A+</b> ASTM E84 <b>Pass</b> Bream® (International, UK, NL, SE, NOR) <b>Exemplary</b> CDPH (CDPH/EHLB/Standard Method V1.2) <b>Pass</b>	
<b>Certifications</b>	Declare label, Cradle to Cradle, UL Environmental Product Declaration, Member of US Green Building Council, Ecobau 1st Priority, Climmate-KIC, VOC emissions in LEED EQ credit (low-emitting products), SCS Recycled Content	
<b>Durability</b>	Contract	

1 - all values are nominal 2 - measured with 300mm air cavity 3 - depending on the location and type of product



Climate-KIC is supported by the EIT, a body of the European Union



**Declare.**



# Alto Ceiling Panels

## Reference application



# Alto Ceiling Panels

## Additional Information

### Online Resources

A variety of resources are available online for all of our products. Please visit the product's page for more information.



CAD files



Spec sheets and  
Installation Guide



Color families



Instruction  
videos



Associated  
products specs.

### Ordering Process

Our experienced team of Project Consultants will guide and support you throughout the order process. We fulfill the majority of our orders in as little as 21 days<sup>1</sup> from your first point of contact, allowing you to focus on what truly matters to you.



Contact our  
consultant

Quote<sup>1</sup>

48h



Order Confirmation

Production<sup>1</sup>

14-21 days



Dispatch

Transit

location based



Delivery

### Contact Us

Ready to make an impact? We are just an email or call away to discuss your project and answer any question.



+41 41 244 14 00



connect@impactacoustic.com



Online form

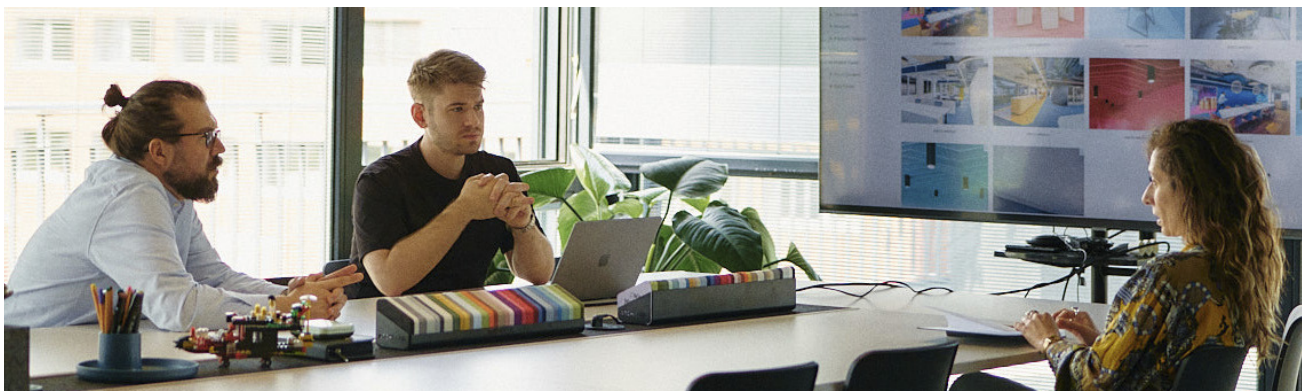

<sup>1</sup> - Quote and Production times may vary.

**IMPACT ACOUSTIC®**  
Alto Ceiling Panels 03.02.25

(Switzerland)  
(USA)  
(Philippines)

connect@impactacoustic.com  
usa@impactacoustic.com  
philippines@impactacoustic.com

(+41) 41 244 14 00  
(+1) 646 918 1581  
(+63) 285 80 02 50

#WeMakeAnImpact

**#We  
Make An  
Impact**

[connect@impactacoustic.com](mailto:connect@impactacoustic.com) | [www.impactacoustic.com](http://www.impactacoustic.com)