

**Liy**

Maximally minimal



Lake villa, Italy / Visualisation: Studio Spacer





Hotel Vista / Visualisation: Studio Spacer

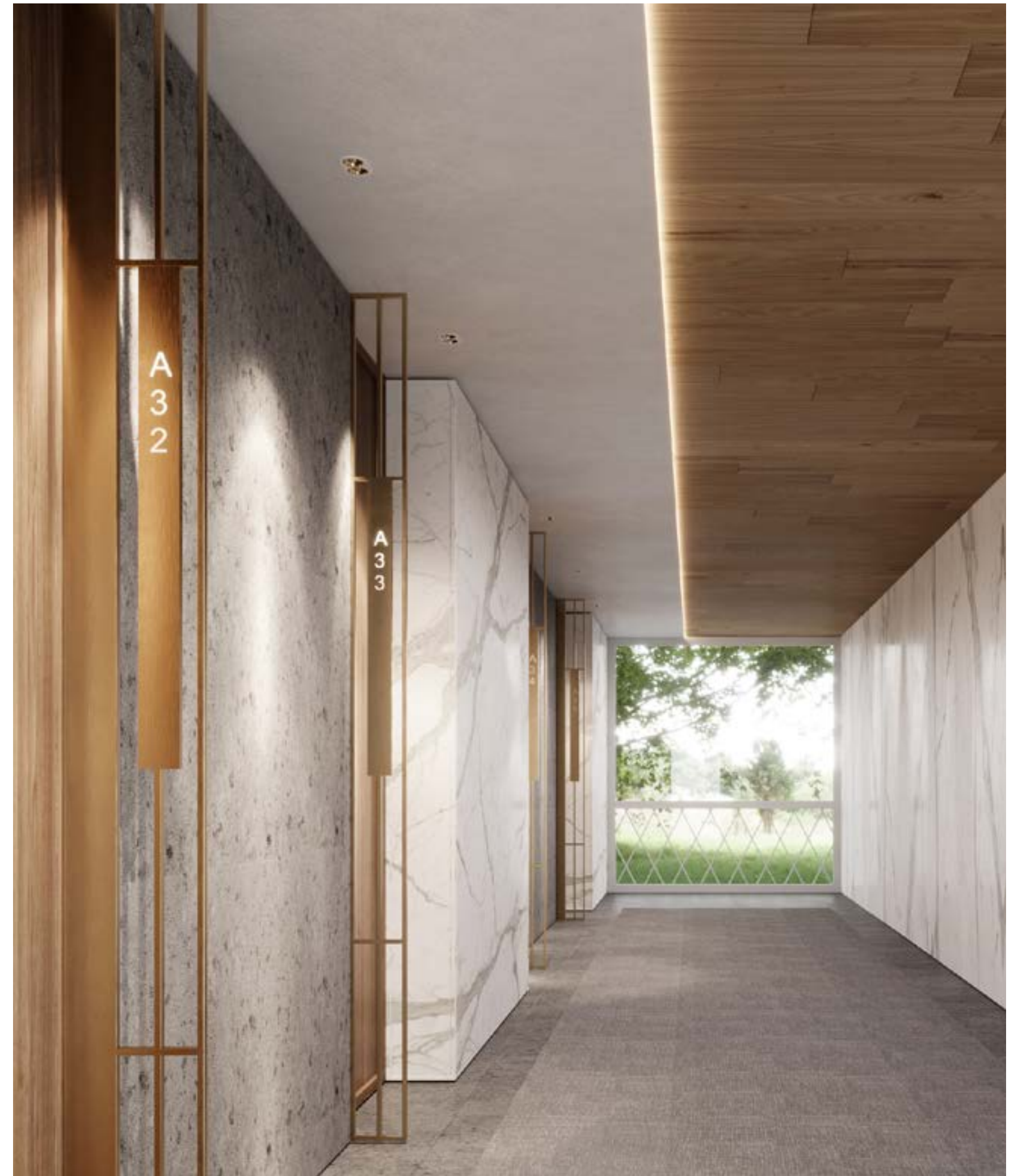

Hotel M / Visualisation: Render Atelier

# Pure light effect

Liy is perfect for elegant spaces where you just can't have an ordinary spot. Its main advantage is the appearance of pure light without any source glare. It is minimalistic. Imagine, the opening on the bottom of the funnel is only 8 mm wide. Then, it depends on the housing colour whether you want the whole luminaire to stand out or to completely blend in.

Liy can perform as a single spot, in a pair, or in a row of three, four or more. It can be fixed or flexible, allowing to change the beam angle and orientation, always having visual attention on the object.

## DESIGN:

Serge Cornelissen



# Family range

---

## LUMINAIRE LUMINOUS FLUX:

up to 190 lm / spot

## LED COLOUR

927, 930, 935, 940

## BEAM ANGLE

LFO 33°, 50°

## IP PROTECTION

IP44



---

54 mm

### RV Fixed

1x, 2x, 3x



---

62 mm

### RI Adjustable

1x



---

80 mm

### RI Adjustable

1x, 2x, 3x

# Double rotation and clean looks

With a simple gesture you can change both, the direction and the inclination angle of the light. In a row of spotlights, you can set each spot individually. And then change it when needed.

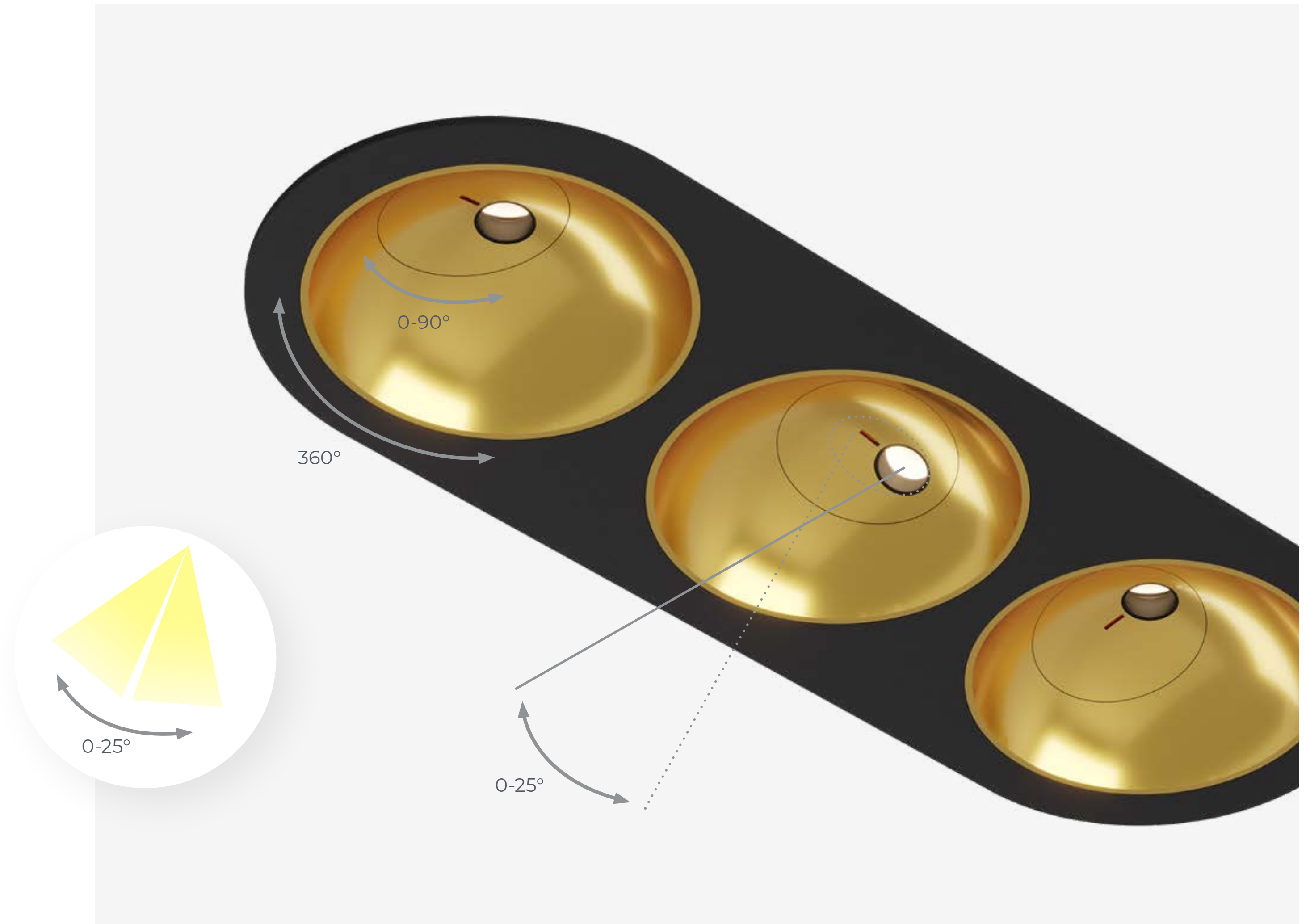

# LFO - A guarantee of maximum visual comfort

Due to special design of Bartenbach LFO optic, all you can see is pure light. The light source is hidden deep inside the optics offering high visual comfort.

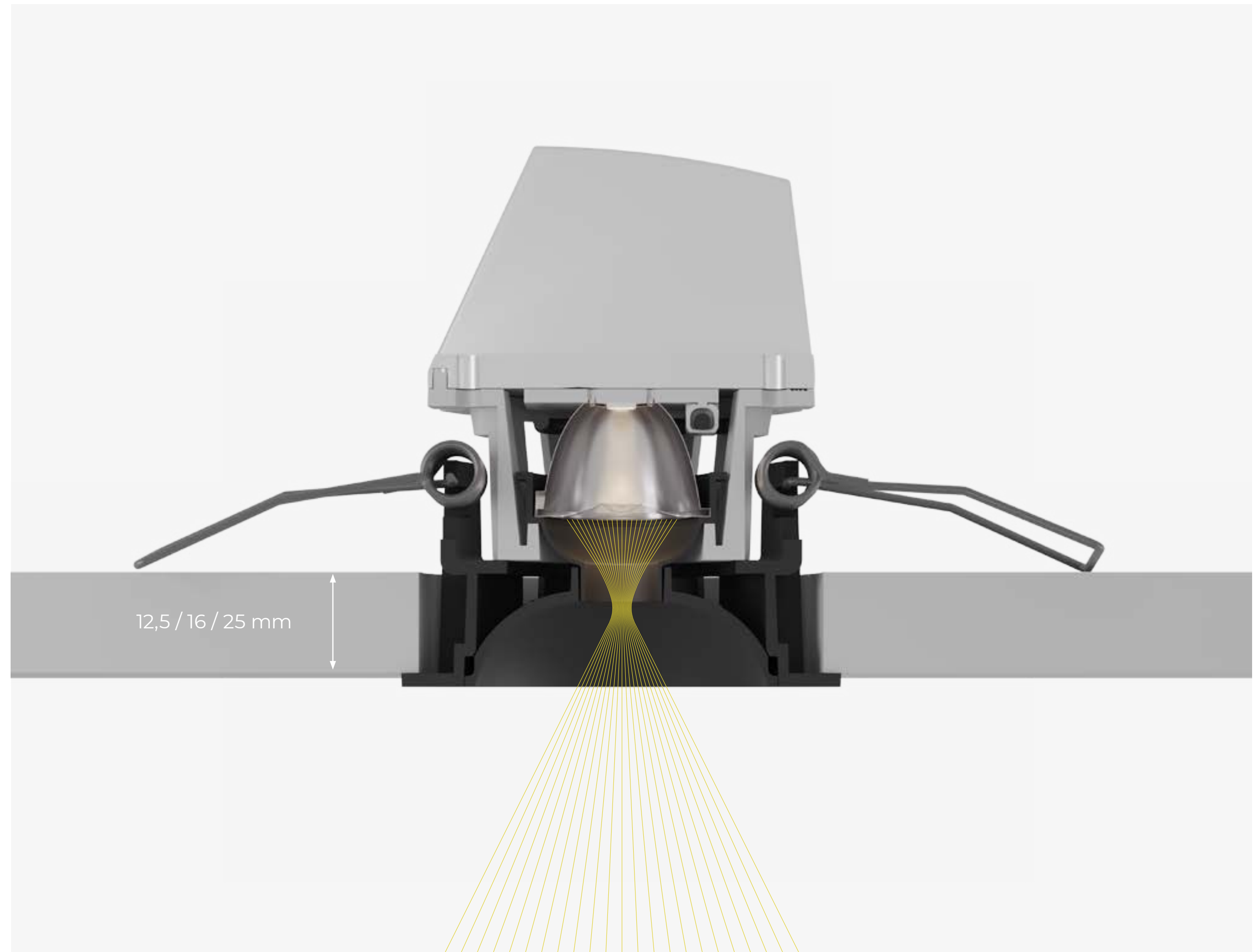

# No double ring

With the Bartenbach LFO optic the light circle is well-defined and homogeneous. At the limits the light intensity is still high.

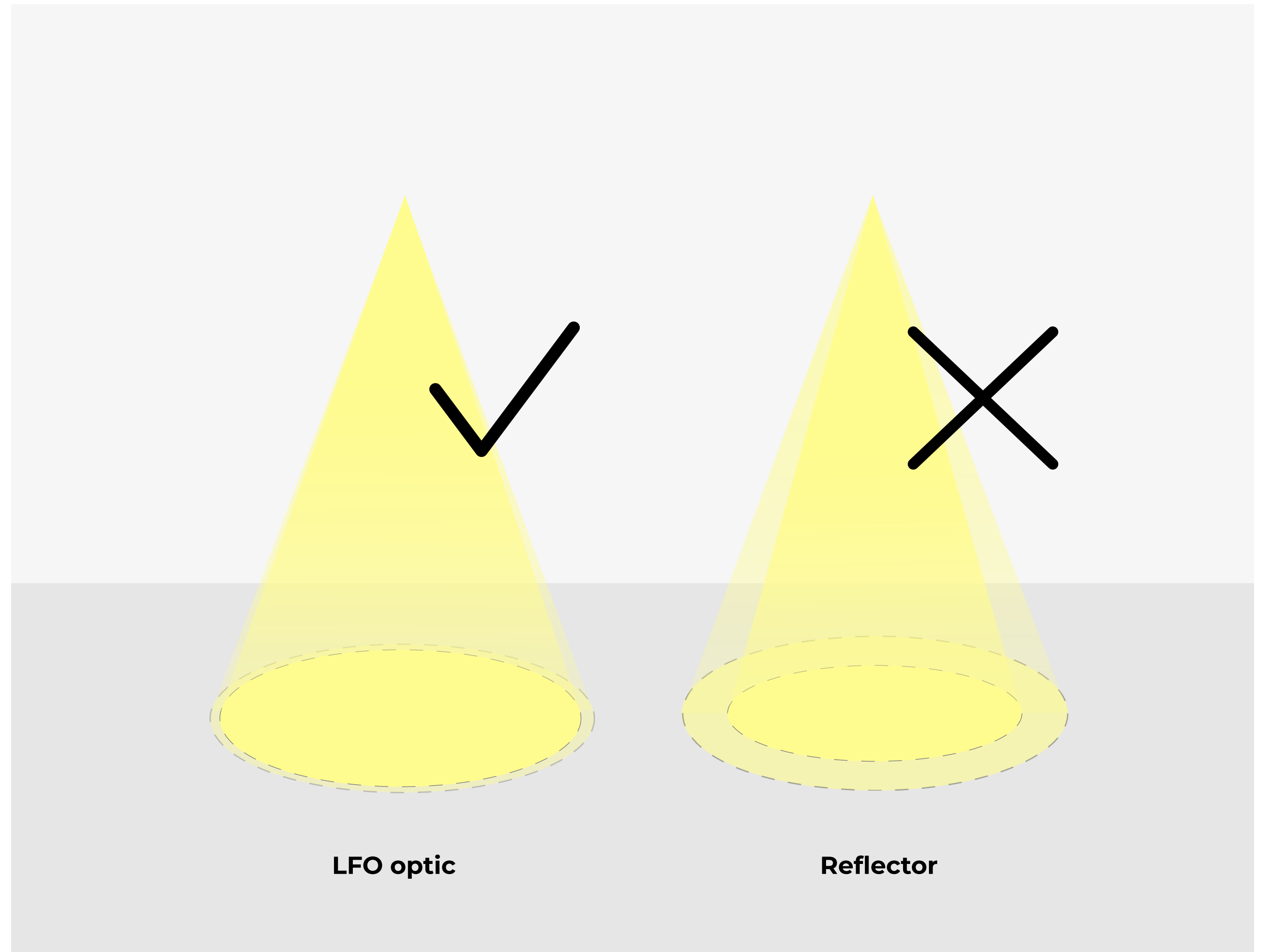

# Trim-less installation

For a precise and clean trim-less installation of two or three spots in a row, you can use the installation kit. In this case the “only light” effect is even greater.



8 mm opening

# Choose the colour that suits you best

Trim colour in white or black; interior colour in black, white or coated colours.





Fixed or adjustable

Pure light without any source glare

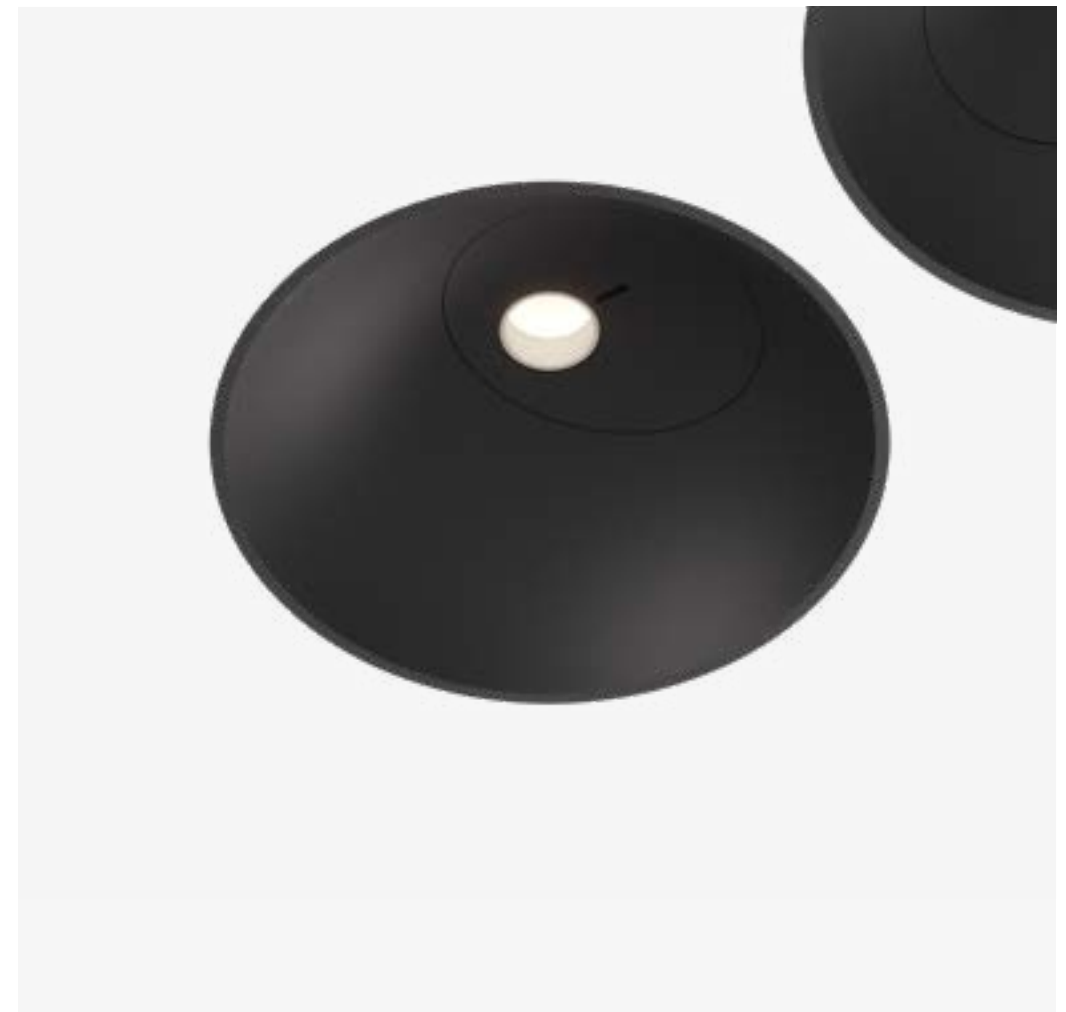

**RI**  
Recessed trim-less



**RV**  
Recessed visible trim



**F**  
Fixed

**A**  
Adjustable

<b>Beam angle</b>	LFO 33°, 50°	LFO 33°, 50°
<b>Orientation</b>	-	25° / 360°
<b>Luminaire luminous flux*</b>	up to 190 lm / spot	up to 190 lm / spot
<b>LED colour</b>	927, 930, 935, 940	927, 930, 935, 940
<b>Driver</b>	Casambi, DALI, FO	Casambi, DALI, FO
<b>Driver position</b>	Remote	Remote
<b>IP protection**</b>	IP44	IP44
<b>Colour</b>	2 H T Y	1 2 H T Y

**Dimensions**

